

Operating Instructions

Wireless Sound System

Model No. **SH-FX80**

Designed for Panasonic DVD Home Theater Sound Systems compatible with the SH-FX80.

Before connecting, operating or adjusting this product, please read the instructions completely. Please keep this manual for future reference.

Dear customer

Thank you for purchasing this product. For optimum performance and safety, please read these instructions carefully.

Wireless 2nd-Room Audio System

page **2**

Enjoy your home theater unit's audio in any room.

Powerful Stand-Alone Audio Amplifier

page **3**

Connect your MP3 player or other digital audio device.

Compatible with Panasonic SH-FX60

page **4**

Easily pair two wireless audio systems for convenient tandem use.

System	SH-FX80
Digital Transceiver	SH-FX80T
Wireless Sound System	SB-FX80

Accessories



Please check and identify the supplied accessories. Use numbers indicated in parentheses when asking for replacement parts. (Product numbers correct as of April 2006. This may be subject to change.)

To order accessories, refer to "Accessory Purchases" on page 5.

- 1 AC power supply cord (K2CB2CB00018)**
For use with this unit only. Do not use it with other equipment. Also, do not use cords for other equipment with this unit.

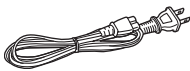

- 1 Cradle screw (XTB3+8GFJ)**



- 2 Cradles for external digital audio players**
1 pocket-type cradle (RGQX0033-H) 1 stand-type cradle (RGPX0257-H)

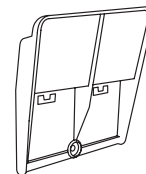
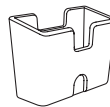

User memo:

DATE OF PURCHASE _____
DEALER NAME _____
DEALER ADDRESS _____
TELEPHONE NUMBER _____

The model number and serial number of this product can be found on either the back or the bottom of the unit. Please note them in the space provided below and keep for future reference.

MODEL NUMBER SH-FX80

SERIAL NUMBER _____



Panasonic Consumer Electronics Company, Division of Panasonic Corporation of North America
One Panasonic Way Secaucus,
New Jersey 07094
<http://www.panasonic.com>

Panasonic Puerto Rico, Inc.
Ave. 65 de Infantería, Km. 9.5
San Gabriel Industrial Park, Carolina,
Puerto Rico 00985

RQT8661-1Y
F0406KN1046

Setup

Preparation

- Turn off all equipment before connection and read the appropriate operating instructions.
- Connect the AC power supply cord after all other connections are complete.

■ Wireless setup diagram

e.g.

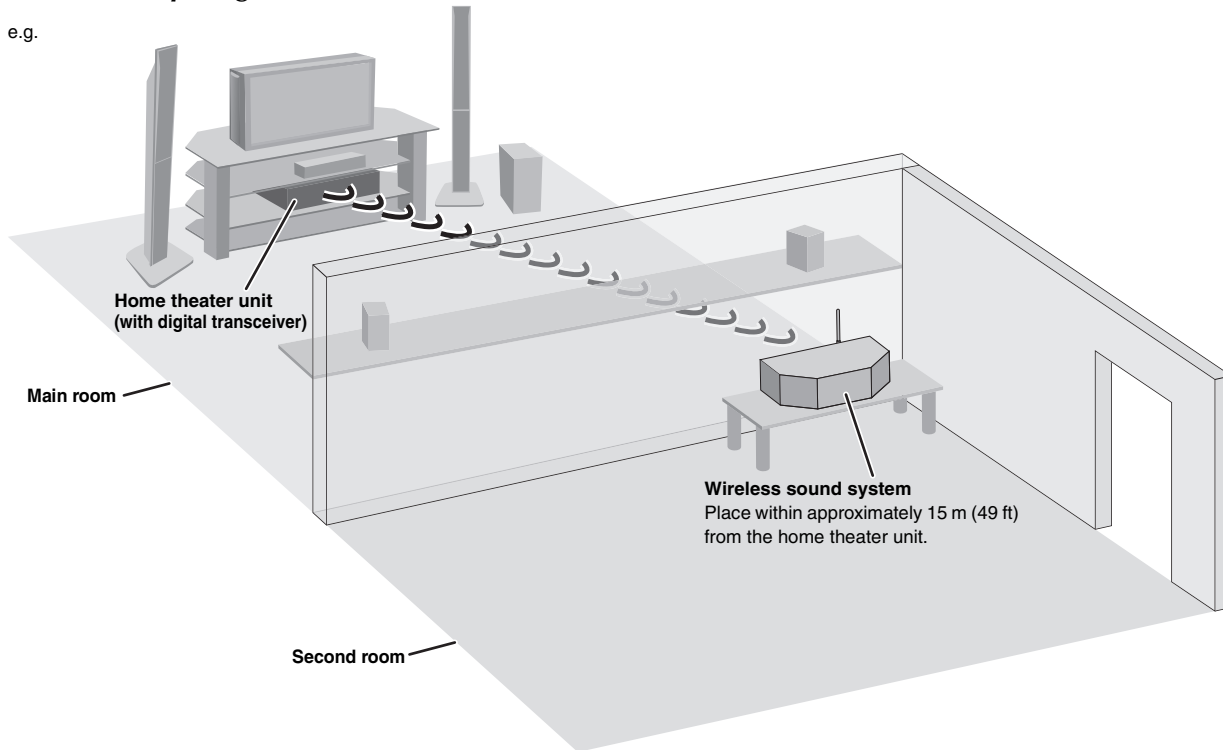

Note

- Do not use the wireless sound system and digital transceiver in a metal cabinet or bookshelf.
- When using the wireless sound system in a separate room, thick or dense walls may reduce the 15 m (49 ft) operating range. If you experience an intermittent link (e.g. sound cutting out), try moving the wireless sound system to a different location nearer to your home theater unit.

■ Avoiding interference

To avoid possible interference, do not place the wireless sound system near any of the following devices.

The wireless sound system uses the same radio frequencies as other devices that may be present in your home.

e.g.

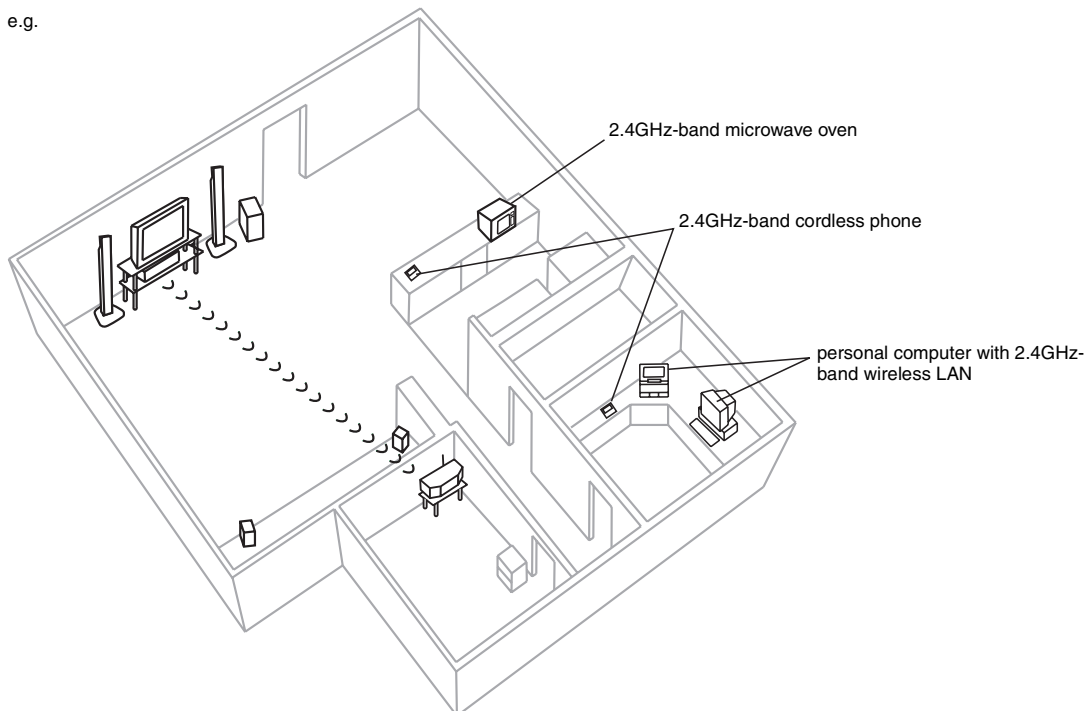

The wireless sound system will automatically seek a clear channel if any of these other devices interfere with its communication. When this happens, the wireless link indicator (e.g. "W" or LED) flashes on your home theater unit, and there is a brief interruption in audio coming from the wireless sound system.

This is the normal operation of the product working to assure the best possible performance of your Home Theater System.

If the interference persists, try moving the other devices to another location outside the range of the wireless sound system.

Connecting the digital transceiver

Insert the digital transceiver into the slot of your home theater unit.

e.g.

Do not insert or remove while the home theater unit is on.

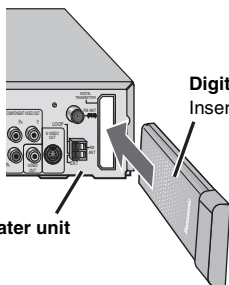

Digital transceiver*
Insert fully until you hear a click.

Rear of the home theater unit

* For SH-FX60 users, do not remove the SH-FX60T transceiver card from the home theater unit. Refer to page 4, "Pairing your SB-FX80 wireless sound system with the SH-FX60 wireless system (not included)".

Connecting the AC cord and setting the sound level

Connect the AC cord to the wireless sound system.

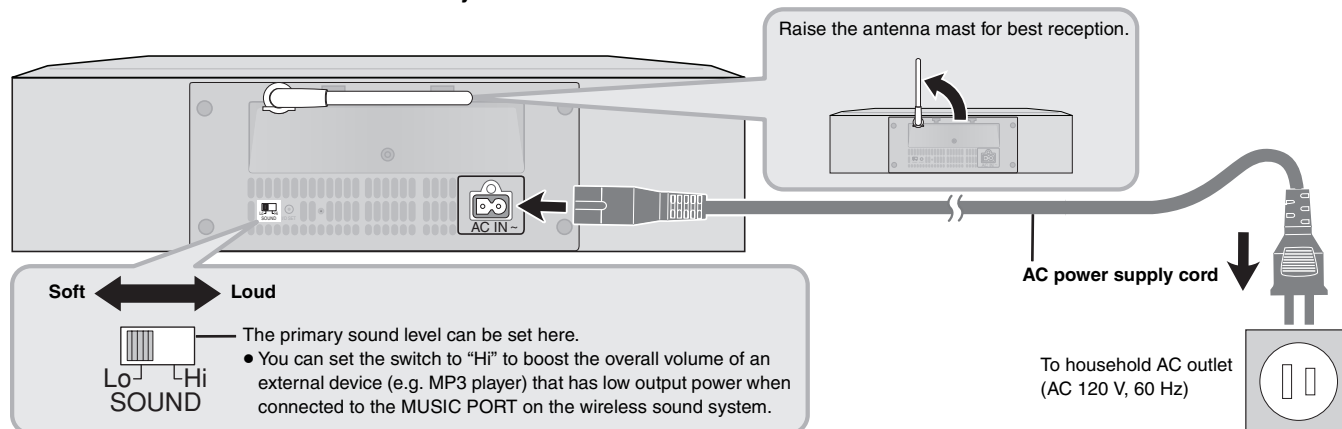

Making the wireless link

Refer also to the operating instructions for your home theater unit.

- 1 Turn on your home theater unit.
 - Ensure the wireless sound system is plugged into the AC outlet.
- 2 Select "MAIN SET" or "MUSIC PORT" on the wireless sound system.

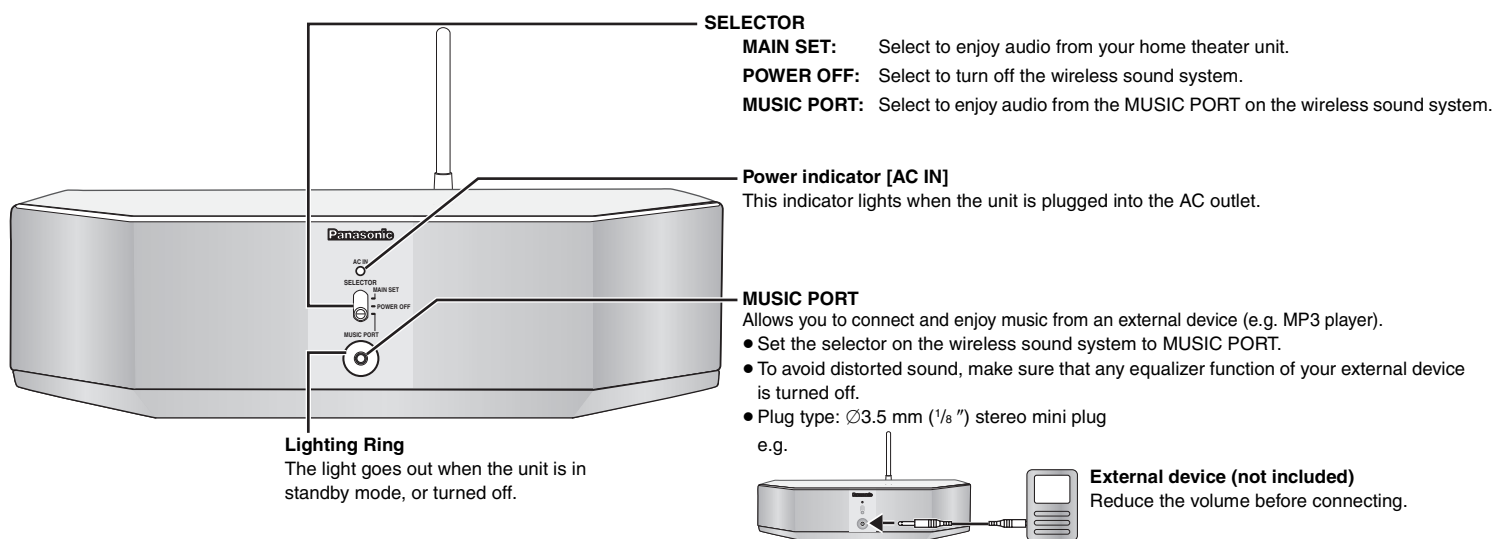

- 3 Check the wireless link indicator on the home theater unit.

The wireless link indicator (e.g. "W" or LED) should light up on the home theater unit.

 - If the indicator is flashing, refer to page 8, Troubleshooting guide.

- 4 Start play on the home theater unit.

Conserving power

The wireless sound system consumes a small amount of power when it is in standby mode. To save power when the unit is not to be used for a long time, unplug it from the household AC outlet.

Attaching the external digital audio player cradle (included)

The wireless sound system can be used as a stand-alone audio amplifier when an external device (e.g. MP3 player) is connected to its MUSIC PORT. To conveniently hold the external device, you can attach the included pocket-type or stand-type cradle.

Unplug the AC cord and disconnect the external device before attaching the cradle.

- ① Hang the cradle on the back of the wireless sound system.
 - Ensure the antenna mast is raised.
- ② Secure the cradle with the screw.

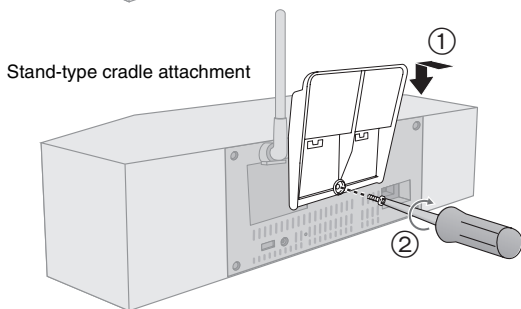
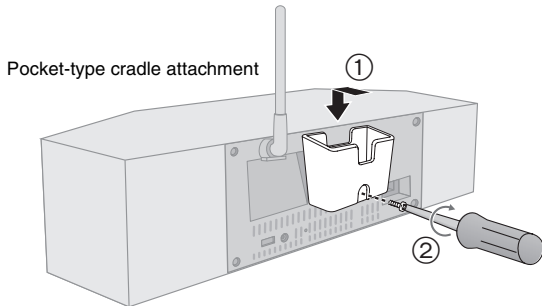

Wireless setup diagram for pairing with the SH-FX60 wireless system

- Your wireless sound system can be used in tandem with the SH-FX60 wireless system.
- To avoid possible interference, refer also to page 2 "Avoiding interference".

e.g.

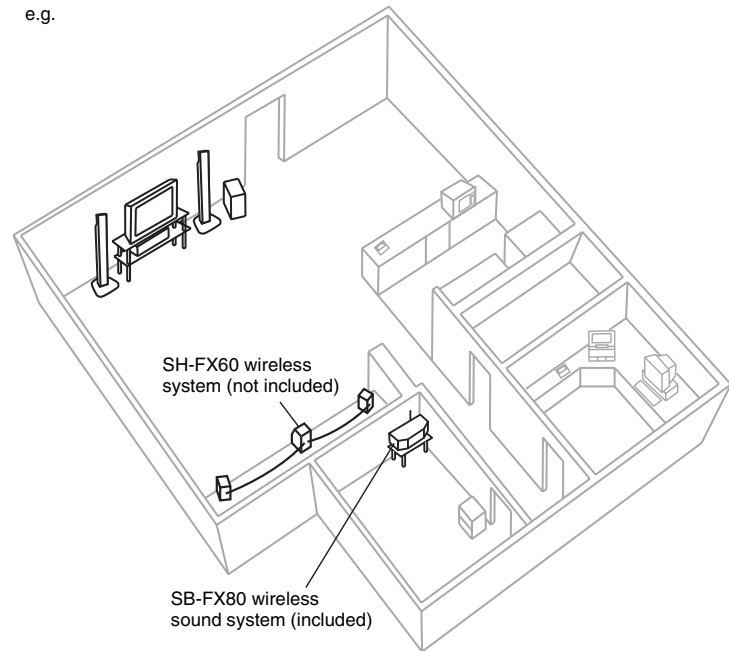

Note

Your wireless sound system can also be used in tandem with the SC-HT640W home theater system. For pairing, you can follow the same procedure as shown below for the SH-FX60 wireless system.

Pairing your SB-FX80 wireless sound system with the SH-FX60 wireless system (not included)

Preparation

- The following steps are to be performed after setting up the SH-FX60 wireless system. For proper setup, refer to its operating instructions.
- **Do not remove the SH-FX60T transceiver card from the home theater unit.**
- Store your SH-FX80T transceiver card in a cool dry place for later use.

- 1 Unplug the SH-FX60 wireless system from the AC outlet.
- 2 Move the SB-FX80 wireless sound system next to your home theater unit.
 - After pairing is completed, you can move the SB-FX80 wireless sound system to the desired location.
- 3 Select "MAIN SET" on the SB-FX80 wireless sound system (→ page 3).
 - Ensure the SB-FX80 wireless sound system is plugged into the AC outlet.
- 4 Reduce the volume on your home theater unit.
- 5 **For HT models** (e.g. SC-HT740)
Press and hold [SURROUND MUSIC] on your home theater unit until "P" lights in the display.
 - Ensure the "REAR MUSIC P." source is not selected.

For RT models (e.g. SC-RT50)

- ① Press [AUX] on your remote control to select "AUX".
- ② Press and hold [■] (Stop) on your home theater unit.
 - Do not release the button.
- ③ Wait at least 5 seconds, and then press [MUTING] on your remote control.
 - "P" lights in the display.
- ④ Release [■] (Stop).

- 6 While "P" is displayed
Using a pointed object, press [I/D SET] on the back of the SB-FX80 wireless sound system.
 - During pairing, the lighting ring will temporarily light up for a short period of time.

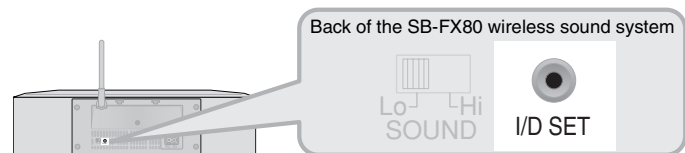

- 7 **Plug the SH-FX60 wireless system back into the AC outlet.**
 - After the SH-FX60 wireless system and SB-FX80 wireless sound system lighting rings both light up, pairing is completed.
 - When paired, the SB-FX80 wireless sound system is linked to your home theater system only when the SH-FX60 wireless system is also linked.

- 8 Start play on your home theater unit.

To cancel pairing, or to use the SB-FX80 wireless sound system without the SH-FX60 wireless system

- ① Turn off your home theater unit.
- ② Swap the SH-FX60T transceiver card with the SH-FX80T transceiver card.
- ③ Turn on your home theater unit.
- ④ Follow steps 2 through 6 (→ above).
 - Pairing is canceled when the lighting ring lights up. The SB-FX80 wireless sound system can now be used without the SH-FX60 wireless system.

Limited Warranty

Panasonic Consumer Electronics Company,
Division of Panasonic Corporation of North America
One Panasonic Way Secaucus, New Jersey 07094

Panasonic Puerto Rico, Inc.
Ave. 65 de Infantería, Km. 9.5
San Gabriel Industrial Park, Carolina, Puerto Rico 00985

Panasonic Audio Products Limited Warranty

Limited Warranty Coverage

If your product does not work properly because of a defect in materials or workmanship, Panasonic Consumer Electronics Company or Panasonic Puerto Rico, Inc. (collectively referred to as "the warrantor") will, for the length of the period indicated on the chart below, which starts with the date of original purchase ("warranty period"), at its option either (a) repair your product with new or refurbished parts, or (b) replace it with a new or a refurbished product. The decision to repair or replace will be made by the warrantor.

Product or Part Name	Parts	Labor
Audio Products (except items listed below)	One (1) year	One (1) year
USB Reader-Writer, Personal Computer Card Adapters (in exchange for defective item)	One (1) year	Not Applicable
Accessories: Headphones, Cartridges, Microphones, Adapters	Ninety (90) days	Ninety (90) days
Rechargeable Batteries, DVD-R/-RAM Discs (in exchange for defective item)	Ten (10) days	Not Applicable
SD Memory Cards, Rechargeable Battery Packs (in exchange for defective item)	Ninety (90) days	Not Applicable

During the "Labor" warranty period there will be no charge for labor. During the "Parts" warranty period, there will be no charge for parts. You must carry-in or mail-in your product during the warranty period. If non-rechargeable batteries are included, they are not warranted. This warranty only applies to products purchased and serviced in the United States or Puerto Rico. This warranty is extended only to the original purchaser of a new product which was not sold "as is". A purchase receipt or other proof of the original purchase date is required for warranty service.

Carry-In or Mail-In Service

For Carry-In or Mail-In Service in the United States call 1-800-211-PANA (1-800-211-7262) or visit Panasonic web site: <http://www.panasonic.com>
For assistance in Puerto Rico call Panasonic Puerto Rico, Inc. (787)-750-4300 or fax (787)-768-2910.

Limited Warranty Limits And Exclusions

This warranty ONLY COVERS failures due to defects in materials or workmanship, and DOES NOT COVER normal wear and tear or cosmetic damage. The warranty ALSO DOES NOT COVER damages which occurred in shipment, or failures which are caused by products not supplied by the warrantor, or failures which result from accidents, misuse, abuse, neglect, mishandling, misapplication, alteration, faulty installation, set-up adjustments, misadjustment of consumer controls, improper maintenance, power line surge, lightning damage, modification, or commercial use (such as in a hotel, office, restaurant, or other business), rental use of the product, service by anyone other than a Factory Servicenter or other Authorized Servicer, or damage that is attributable to acts of God.

THERE ARE NO EXPRESS WARRANTIES EXCEPT AS LISTED UNDER "LIMITED WARRANTY COVERAGE". THE WARRANTOR IS NOT LIABLE FOR INCIDENTAL OR CONSEQUENTIAL DAMAGES RESULTING FROM THE USE OF THIS PRODUCT, OR ARISING OUT OF ANY BREACH OF THIS WARRANTY. (As examples, this excludes damages for lost time, travel to and from the servicer, loss of media or images, data or other memory content. The items listed are not exclusive, but are for illustration only.) **ALL EXPRESS AND IMPLIED WARRANTIES, INCLUDING THE WARRANTY OF MERCHANTABILITY, ARE LIMITED TO THE PERIOD OF THE LIMITED WARRANTY.**

Some states do not allow the exclusion or limitation of incidental or consequential damages, or limitations on how long an implied warranty lasts, so the exclusions may not apply to you. This warranty gives you specific legal rights and you may also have other rights which vary from state to state. If a problem with this product develops during or after the warranty period, you may contact your dealer or Servicenter. If the problem is not handled to your satisfaction, then write to the warrantor's Consumer Affairs Department at the addresses listed for the warrantor.

PARTS AND SERVICE WHICH ARE NOT COVERED BY THIS LIMITED WARRANTY ARE YOUR RESPONSIBILITY.

Customer Services Directory

Obtain Product Information and Operating Assistance; locate your nearest Dealer or Servicenter; purchase Parts and Accessories; or make Customer Service and Literature requests by visiting our Web Site at:

<http://www.panasonic.com/consumersupport>

or, contact us via the web at:

<http://www.panasonic.com/contactinfo>

You may also contact us directly at:

1-800-211-PANA (7262),

Monday-Friday 9 am-9 pm; Saturday-Sunday 10 am-7 pm, EST.

For hearing or speech impaired TTY users, TTY : 1-877-833-8855

Accessory Purchases

Purchase Parts, Accessories and Instruction Books online for all Panasonic Products by visiting our Web Site at:

<http://www.pasc.panasonic.com>

or, send your request by E-mail to:

npcparts@us.panasonic.com

You may also contact us directly at:

1-800-332-5368 (Phone) 1-800-237-9080 (Fax Only) (Monday – Friday 9 am to 8 pm, EST.)

Panasonic Services Company

20421 84th Avenue South, Kent, WA 98032

(We Accept Visa, MasterCard, Discover Card, American Express, and Personal Checks)

For hearing or speech impaired TTY users, TTY : 1-866-605-1277

Service in Puerto Rico

Panasonic Puerto Rico, Inc.

Ave. 65 de Infantería, Km. 9.5, San Gabriel Industrial Park, Carolina, Puerto Rico 00985

Phone (787)750-4300, Fax (787)768-2910

WARNING:

TO REDUCE THE RISK OF FIRE, ELECTRIC SHOCK OR PRODUCT DAMAGE, DO NOT EXPOSE THIS APPARATUS TO RAIN, MOISTURE, DRIPPING OR SPLASHING AND THAT NO OBJECTS FILLED WITH LIQUIDS, SUCH AS VASES, SHALL BE PLACED ON THE APPARATUS.

CAUTION!

DO NOT INSTALL OR PLACE THIS UNIT IN A BOOKCASE, BUILT-IN CABINET OR IN ANOTHER CONFINED SPACE. ENSURE THE UNIT IS WELL VENTILATED. TO PREVENT RISK OF ELECTRIC SHOCK OR FIRE HAZARD DUE TO OVERHEATING, ENSURE THAT CURTAINS AND ANY OTHER MATERIALS DO NOT OBSTRUCT THE VENTILATION VENTS.

The socket outlet shall be installed near the equipment and easily accessible. The mains plug of the power supply cord shall remain readily operable.
To completely disconnect this apparatus from the AC Mains, disconnect the power supply cord plug from AC receptacle.



CAUTION

**RISK OF ELECTRIC SHOCK
DO NOT OPEN**



CAUTION: TO REDUCE THE RISK OF ELECTRIC SHOCK, DO NOT REMOVE SCREWS. NO USER-SERVICEABLE PARTS INSIDE.
REFER SERVICING TO QUALIFIED SERVICE PERSONNEL.



The lightning flash with arrowhead symbol, within an equilateral triangle, is intended to alert the user to the presence of uninsulated "dangerous voltage" within the product's enclosure that may be of sufficient magnitude to constitute a risk of electric shock to persons.



The exclamation point within an equilateral triangle is intended to alert the user to the presence of important operating and maintenance (servicing) instructions in the literature accompanying the appliance.

FCC Note:

This equipment has been tested and found to comply with the limits for a Class B digital device, pursuant to Part 15 of the FCC Rules.

These limits are designed to provide reasonable protection against harmful interference in a residential installation. This equipment generates, uses and can radiate radio frequency energy and, if not installed and used in accordance with the instructions, may cause harmful interference to radio communications.

However, there is no guarantee that interference will not occur in a particular installation. If this equipment does cause harmful interference to radio or television reception, which can be determined by turning the equipment off and on, the user is encouraged to try to correct the interference by one or more of the following measures:

- Reorient or relocate the receiving antenna.
- Increase the separation between the equipment and receiver.
- Connect the equipment into an outlet on a circuit different from that to which the receiver is connected.
- Consult the dealer or an experienced radio/TV technician for help.

FCC caution: To maintain compliance with FCC regulations, shielded interface cables must be used with this equipment. Operation with non-approved equipment or unshielded cables may result in interference to radio and TV reception. Any changes or modifications not approved by the party responsible for compliance could void the user's authority to operate this equipment.

This device complies with Part 15 of the FCC Rules. Operation is subject to the following two conditions:

- (1) This device may not cause harmful interference, and
- (2) this device must accept any interference received, including interference that may cause undesired operation.

Responsible Party:

Panasonic Corporation of North America
One Panasonic Way
Secaucus, NJ 07094
Telephone No.: 1-800-211-7262



WARNING:

To satisfy FCC RF exposure requirements for mobile transmitting devices, a separation distance of 20 cm or more should be maintained between the antenna of this device and persons during device operation. To ensure compliance, operations at closer than this distance is not recommended. The antenna used for this transmitter must not be co-located in conjunction with any other antenna or transmitter.

This device complies with Part 15 of the FCC Rules. Operation is subject to the following two conditions:

- (1) This device may not cause harmful interference,
- (2) This device must accept any interference received, including interference that may cause undesired operation.

IMPORTANT SAFETY INSTRUCTIONS

Read these operating instructions carefully before using the unit. Follow the safety instructions on the unit and the applicable safety instructions listed below. Keep these operating instructions handy for future reference.

- 1) Read these instructions.
- 2) Keep these instructions.
- 3) Heed all warnings.
- 4) Follow all instructions.
- 5) Do not use this apparatus near water.
- 6) Clean only with dry cloth.
- 7) Do not block any ventilation openings. Install in accordance with the manufacturer's instructions.
- 8) Do not install near any heat sources such as radiators, heat registers, stoves, or other apparatus (including amplifiers) that produce heat.
- 9) Do not defeat the safety purpose of the polarized or grounding-type plug. A polarized plug has two blades with one wider than the other. A grounding-type plug has two blades and a third grounding prong. The wide blade or the third prong are provided for your safety. If the provided plug does not fit into your outlet, consult an electrician for replacement of the obsolete outlet.
- 10) Protect the power cord from being walked on or pinched particularly at plugs, convenience receptacles, and the point where they exit from the apparatus.

- 11) Only use attachments/accessories specified by the manufacturer.
- 12) Use only with the cart, stand, tripod, bracket, or table specified by the manufacturer, or sold with the apparatus. When a cart is used, use caution when moving the cart/apparatus combination to avoid injury from tip-over.
- 13) Unplug this apparatus during lightning storms or when unused for long periods of time.
- 14) Refer all servicing to qualified service personnel. Servicing is required when the apparatus has been damaged in any way, such as power-supply cord or plug is damaged, liquid has been spilled or objects have fallen into the apparatus, the apparatus has been exposed to rain or moisture, does not operate normally, or has been dropped.



- If you see this symbol-

Information on Disposal in other Countries outside the European Union



This symbol is only valid in the European Union.
If you wish to discard this product, please contact your local authorities or dealer and ask for the correct method of disposal.

Product service

1. **Damage requiring service**—The unit should be serviced by qualified service personnel if:
 - (a) The AC power supply cord or AC adaptor has been damaged; or
 - (b) Objects or liquids have gotten into the unit; or
 - (c) The unit has been exposed to rain; or
 - (d) The unit does not operate normally or exhibits a marked change in performance; or
 - (e) The unit has been dropped or the cabinet damaged.
2. **Servicing**—Do not attempt to service the unit beyond that described in these operating instructions. Refer all other servicing to authorized servicing personnel.
3. **Replacement parts**—When parts need replacing ensure the servicer uses parts specified by the manufacturer or parts that have the same characteristics as the original parts. Unauthorized substitutes may result in fire, electric shock, or other hazards.
4. **Safety check**—After repairs or service, ask the servicer to perform safety checks to confirm that the unit is in proper working condition.

The servicer will require all components to service your system.

Therefore, should service ever be necessary, be sure to bring the entire system.

Product information

For product information or assistance with product operation:

Refer to “*Customer Services Directory*” on page 5.

Maintenance

Clean this unit with a soft, dry cloth.

- Never use alcohol, paint thinner or benzene to clean this unit.
- Before using chemically treated cloth, carefully read the instructions that came with the cloth.

Troubleshooting guide

Before requesting service, make the following checks. If you are in doubt about some of the check points, or if the solutions indicated in the table do not solve the problem, refer to the "Customer Services Directory" on page 5.

On your home theater unit

The wireless link indicator (e.g. "W" or LED) does not light.	<ul style="list-style-type: none"> Ensure that the digital transceiver is fully inserted into the slot of the home theater unit. Check that the home theater unit is turned on.
The wireless link indicator (e.g. "W" or LED) is flashing.	<ul style="list-style-type: none"> There is no link between the home theater unit and the wireless sound system. Check that the wireless sound system is plugged into the AC outlet. Ensure that the selector on the wireless sound system is set to MAIN SET. Ensure that the wireless sound system is within 15 m (49 ft) of the home theater unit. When the SH-FX60 wireless system is paired with the SB-FX80 wireless sound system, ensure that the SH-FX60 is plugged into the AC outlet.
There is no sound when the selected source on the home theater unit is "REAR MUSIC P."	<ul style="list-style-type: none"> The "REAR MUSIC P." source is not available for the SH-FX80 wireless sound system. To play audio from an external device through your home theater unit, connect to the MUSIC PORT on the home theater unit and select "FRONT MUSIC P." as the source. (Refer also to your home theater unit's operating instructions.) When using the wireless sound system as a stand-alone audio amplifier, ensure that the selector on the wireless sound system is set to MUSIC PORT.
The wireless link indicator (e.g. "W" or LED) is lit, but there is no sound from the SB-FX80 wireless sound system.	<ul style="list-style-type: none"> When playing from a 2-channel audio source (e.g. AM/FM station, music CD, etc.), turn on one of the surround sound effects of your home theater system (e.g. SURROUND MUSIC) in order to utilize all audio channels. (Refer also to your home theater unit's operating instructions.) When using the wireless sound system as a stand-alone audio amplifier, ensure that the selector on the wireless sound system is set to MUSIC PORT. When the SH-FX60 wireless system is paired with the SB-FX80 wireless sound system, the wireless link indicator on your home theater unit (e.g. "W" or LED) will light when there is a link with the SH-FX60, even when there is no link with the SB-FX80. <ol style="list-style-type: none"> Check that the SB-FX80 is plugged into the AC outlet. Ensure that the selector on the SB-FX80 is set to MAIN SET. Ensure that the SB-FX80 is within 15 m (49 ft) of the home theater unit. Adjust the volume of your home theater unit. If there is still no sound, repeat the pairing procedure on page 4.
The wireless link indicator (e.g. "W" or LED) is lit, but there is no sound from the SH-FX60 wireless system.	<ul style="list-style-type: none"> When playing from a 2-channel audio source (e.g. AM/FM station, music CD, etc.), turn on one of the surround sound effects of your home theater system (e.g. SURROUND MUSIC) in order to utilize all audio channels. (Refer also to your home theater unit's operating instructions.) The wrong transceiver card has been inserted into the home theater unit. (The SH-FX80T transceiver card cannot be used with the SH-FX60 wireless system.) <ol style="list-style-type: none"> Turn off your home theater system, remove the SH-FX80T transceiver card, and insert the SH-FX60T transceiver card. Turn on your home theater system, and then follow the pairing procedure on page 4. Adjust the volume of your home theater unit.
After pairing the SB-FX80 wireless sound system with the SH-FX60 wireless system, audio output is erratic.	<ul style="list-style-type: none"> Ensure that the SH-FX60 wireless system is unplugged, and then repeat the pairing procedure on page 4.

Specifications

AMPLIFIER SECTION

Output power

RMS output power stereo mode	
Surround Ch (both ch driven)	65 W per channel (4 Ω), 1 kHz, 10 % THD
Total RMS stereo mode power	130 W
FTC output power stereo mode	
Surround Ch (both ch driven)	40 W per channel (4 Ω), 120 Hz–20 kHz, 1 % THD
Total FTC stereo mode power	80 W

SPEAKER SECTION

Surround speakers SB-FX80

Type	1 way, 1 speaker system (Bass reflex) (L and R ch in one box)
Speaker unit(s)	Impedance 4 Ω 6.5 cm (2 1/2") Cone type
Input power (IEC)	90 W* (Max)
Output sound pressure	80 dB/W (1.0 m)
Frequency range	100 Hz–25 kHz (–16 dB) 115 Hz–22 kHz (–10 dB)

RF SECTION

Wireless module

Frequency range	2.436 to 2.458 GHz
RF output power	19 dBm (Max)

MUSIC PORT terminal

Input sensitivity	100 mV
Input impedance	4.7 kΩ
Terminal	Stereo, 3.5 mm (1/8") jack

GENERAL

Power supply	AC 120 V, 60 Hz
Power consumption	Digital transceiver 0.85 W Wireless sound system 30 W
Dimensions (W×H×D)	Digital transceiver 97 mm×47.5 mm×8.5 mm (3 13/16"×1 7/8"×1 1/32") Wireless sound system 430 mm×197.5 mm×174.5 mm (16 15/16"×7 25/32"×6 7/8")
Mass	Digital transceiver 0.03 kg (0.07 lbs) Wireless sound system 2.7 kg (6 lbs)
Operating temperature range	+5 °C to +35 °C (+41 °F to +95 °F)
Operating humidity range	5 % to 90 % RH (no condensation)

Power consumption in standby mode	3 W
--	-----

* Rating with low-cut filter equipped amplifier

Note

- Specifications are subject to change without notice. Mass and dimensions are approximate.
- Total harmonic distortion is measured by a digital spectrum analyzer.